

**Nota:**  
-cofrarea se va executa in conformitate cu  
"Cod de practica pentru executarea lucrarilor  
din beton, beton armat si beton  
precomprimat - Indicativ NE 012 / 2010".  
-stratul de acoperire cu beton va fi de 2.5 cm

**Materiale:**  
Otel : PC 52, OB 37  
Beton: C 16/20 (Bc 20)-P4-T3-CEM II/A-S 32.5R/0-31  
C 25/30 (Bc 30)-P4-T3-CEM II/A-S 32.5R/0-16  
Clasa de expunere: Xc1+Xc2,Xc4

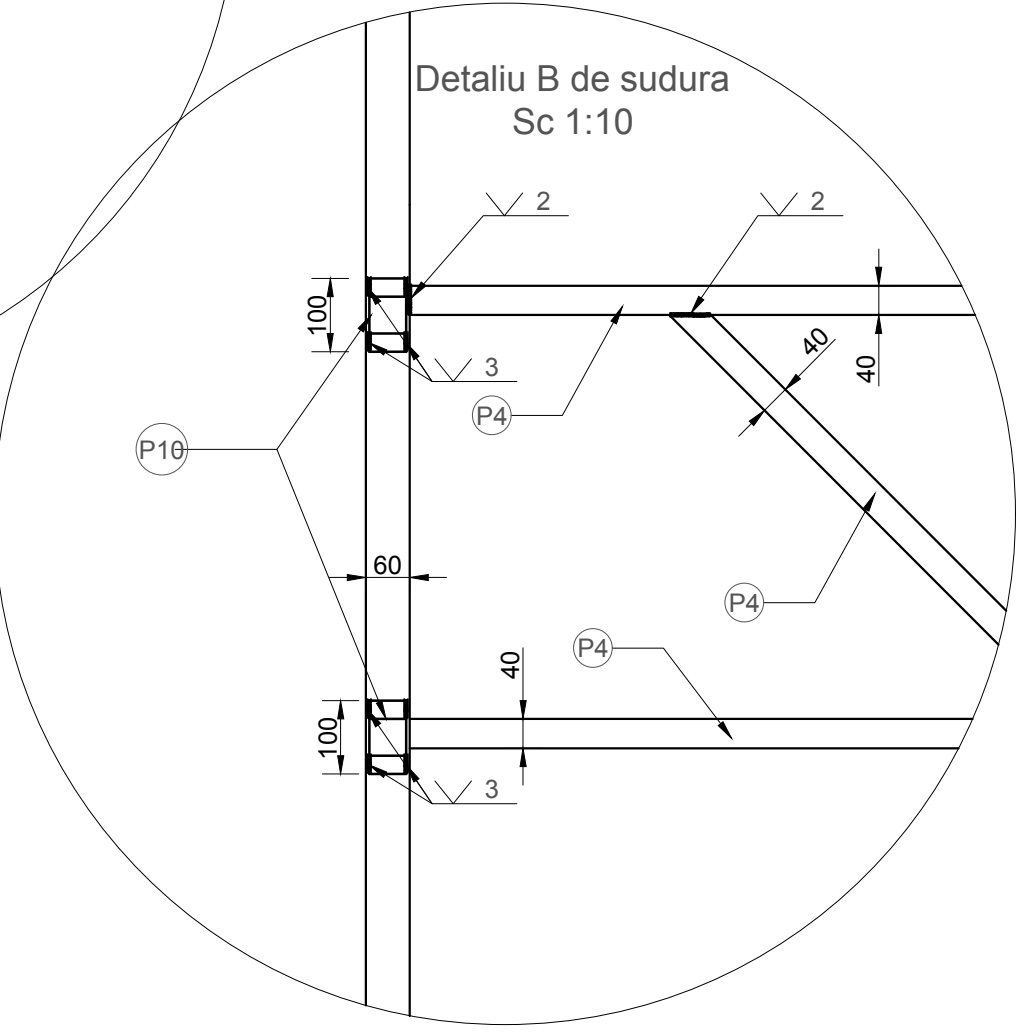
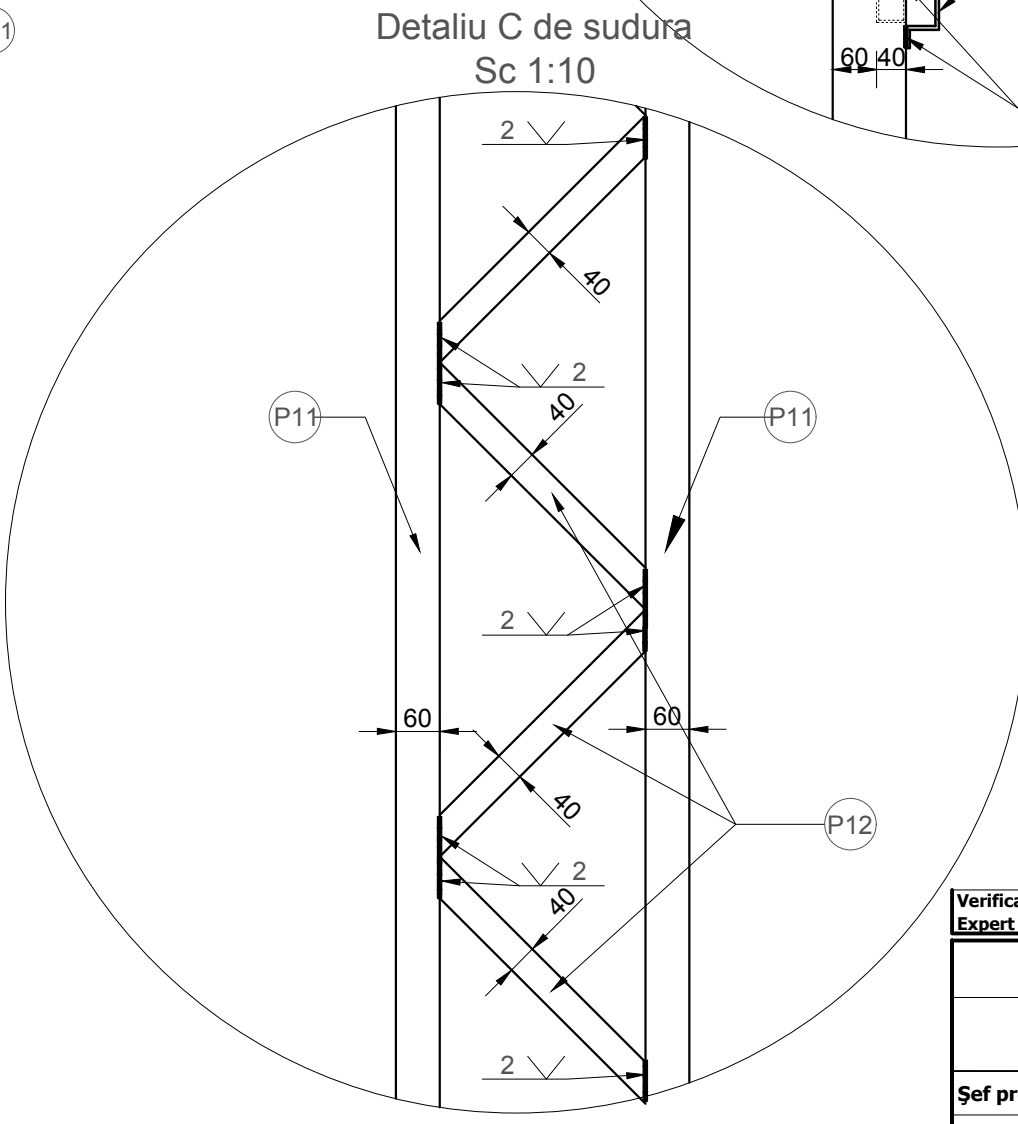
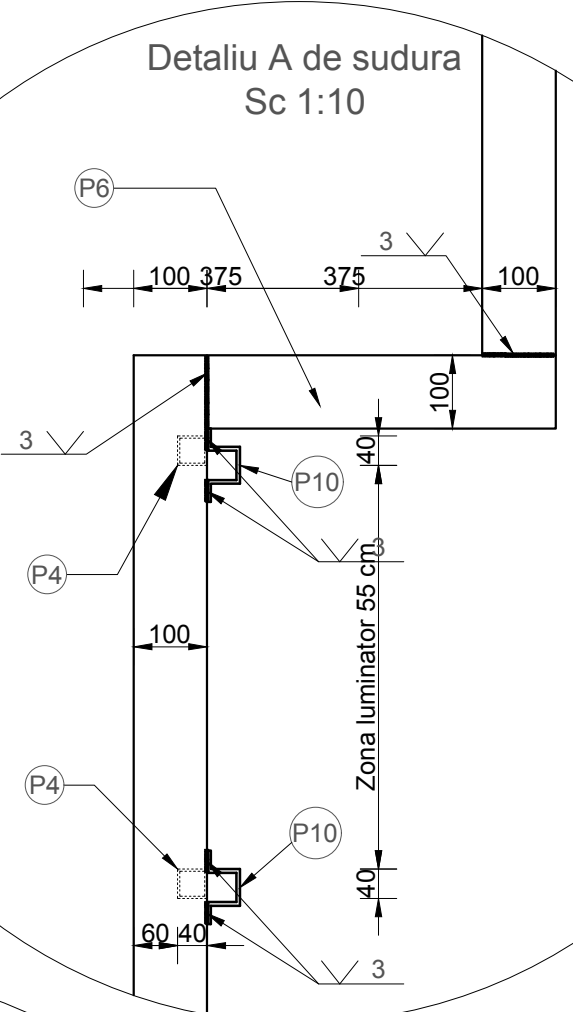

**Materiale:**  
Otel : OL 37(S235JR)  
Categoria de executie -B conf. STAS 767/0-88;  
Clasa de taiere a elementelor: 1.1.1 conf STAS 10564/1-81;  
Nivelul de acceptare a imbinarilor sudate: C2-conf. C150/99;  
Electrozi pentru sudura E44-227Tm 1.1 conf. STAS 1125/1-91;

**Cupluri de strangere pentru suruburi si piulite:**  
-M14: 125Nm

**Nota:**  
- Piesele metalice vor fi vopsite cu vopsea anticoroziva.  
-Clasa de rezistenta la suruburi si piulite: 8.8

|  |                         |  |   |
|--|-------------------------|--|---|
| Verificator/<br>Expert   |                         | Cerinta:   | REFERAT/EXPERTIZA/ NR. DATA   |
| <b>FORVERSZKI NORBERT JOZSEF-PROFORCONS</b><br><b>PERSOANA FIZICA AUTORIZATA</b> |                         | <b>Beneficiar:</b> S.C. ADMINISTRATIA DOMENIUL PUBLICA S.A.<br>repr. prin ANDRICA LIVIU                                | Proiect nr.<br>2/2016   |
| Jud. Bihor, Mun. Oradea, Str. Piata Unirii, Nr.5,<br>et.1, Ap.12                 |                         | <b>Titlu proiect :</b> MODERNIZARE PIATA AGORALIMENTARA CETATE<br>INCHIDERE COPERTINA EXISTENTA LATURA NORD-EST        | Faza:<br>D.T.A.C.   |
| Telefon: 0752/223.502. Email: proforcons@yahoo.ro                                |                         | <b>Amplasament :</b> Mun.: Oradea, Str.: Piata Independentei, Nr.: 21,<br>Piata Cetate, NR.TOPO.: 3582/15, Jud.: Bihor | +P.T+C.S.   |
| <b>Şef proiect</b>   | arh. DEMIAN ZSOLT       | Scara:<br>1:20<br>1:10   | <b>Titlu plansa:</b><br>-rezistenta-  |
| <b>Proiectat</b>   | ing. FORVERSZKI NORBERT | 2015   | <b>Detalii sectiune 7-7 si detaliu</b><br><b>tip acces de 2.02 m.</b><br><b>Detalii A; B si C de sudura</b> |
| <b>Desenat</b>   | ing. FORVERSZKI NORBERT |  |   |